

2010

David Gitz, EE
Dr. Michael Welling, EE

Comment [DPG1]: Picture choppy in pdf

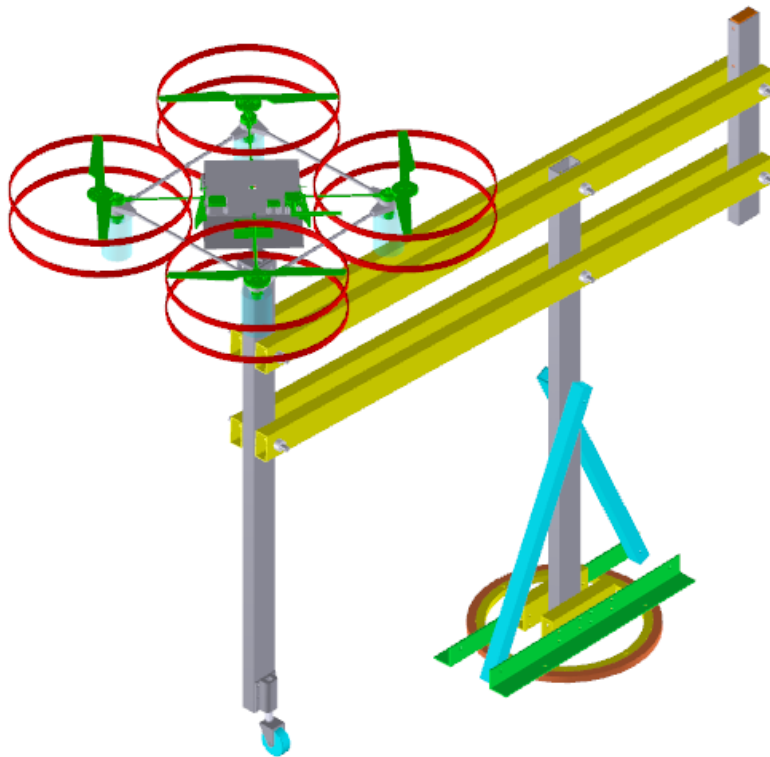

ROBO-CHOPPER DESIGN REPORT

Contents

Contents.....	1
Executive Summary.....	3
Suggested Customer Applications	4
Request	4
Project Management	5
Budget	5
Team Coordination	5
Project Schedule	6
Phase Schedule	6
Engineering	9
Design Challenges	9
Communications	9
Multiple-Controller Implementation	12
Flight Power Capabilities.....	13
Control Algorithm	14
Test Plans	19
System-Vehicle.....	23
Summary	24
Budget.....	26
Action Item List	27
System Overview.....	Error! Bookmark not defined.
Subsystem – Sensors.....	28
Overview	28
Component Selection and Specifications:	28
Subsystem – Power	31
Overview	32
Component Selection and Specifications:	32
Subsystem – Frame	33
Overview	33
Component Selection and Specifications:	33
Subsystem – Control Board.....	34
Overview	34

Component Selection and Specifications:	34
Subsystem – Communications	35
Overview	35
Component Selection and Specifications:	35
System – Remote Control Unit (RCU)	36
Summary	36
Budget	36
Action Item List	37
Overview	37
System – Test Stand	39
Summary	39
Budget	39
Action Item List	40
Subsystem – Frame	41
Overview	41
Component Selection and Specifications	42
Subsystem – Force Measurement	42
Overview	42
Component Selection and Specifications	42
Subsystem – Electronics	42
Overview	42
Component Selection and Specifications	42
Subsystem – Test Fixture Assembly	43
Overview	43
Component Selection and Specifications	43
System – Ground Control Station	43
Summary	43
Budget	45
Action Item List	45
Subsystem – Case	46
Overview	46
Component Selection and Specifications	48
Subsystem – Power	48

Overview	48
Component Selection and Specifications	48
Subsystem – Communications	49
Overview	49
Component Selection and Specifications	49
Subsystem – Control	49
Overview	49
Component Selection and Specifications	49
References	51
Appendix	51
Figures.....	52
Tables.....	53

Executive Summary

The field of Robotics is quickly developing into a mature field. Land-based robots have been in development for the past 20 [ref] years, but flying robots are fairly new to society. Surveying, scouting, reconnaissance, disaster relief and military purposes are all outstanding applications of flying robots. The number of uses of flying robots is only matched by the number of their complexities. Weight, maneuverability, dynamic control systems and power constraints are all very dominant issues in the implementation of flying robots.

Comment [DPG2]:

Two main classes of flying robots exist, airplane and hovercraft. While airplane robots are capable of much longer range, increased payload and simpler control systems, they suffer from their limitations of maneuverability over small areas, takeoff/landing facilities and the ability to hover over fixed areas. Hovercraft robots, such as helicopters, eliminate these constraints with the limitation of decreased range, decreased payload and more advanced control systems. A Quad-Rotor helicopter reduces the need for a mechanically advanced helicopter control system by using 4 counter-rotating rotor blades, although again decreasing flight time and payload capacity. The Vehicle in this Design Report is based on a Quad-Rotor design.

Suggested Customer Applications

There are many applications for the Robo-Chopper, see Table 1: Suggested Customer Applications for a short list. Please note that the Robo-Chopper is a system with continually expanding features and the applications for this device are endless.

Table 1: Suggested Customer Applications

<i>Industry</i>	<i>Application</i>
Home Inspecting	Roof and Exterior Surveying
Civil Engineering	Bridge Inspection
Law Enforcement	Search, Crime Scene Investigation
Military	Reconnaissance
Hobbyists	Development Platform – Completely Open Source
Environmental	Nature Surveying and Data Collection
Emergency Management	Searching and Reconnaissance

Request

As detailed in the Project Management - Budget Section, this Project is currently projected to cost \$2,200.00 to complete one complete System. As we feel that this Project offers many benefits to the XX Organization, we would like to request \$XXXX.XX to support this Project.

Comment [DPG3]:

Comment [DPG4]:

Also, as this Project deals with many different areas of knowledge and all require expertise in their fields, we would like to request the support of any of your staff that could offer assistance with the development of this Project. Specifically, we are looking for the skill-sets in Table 2: Skill-sets Desired

Table 2: Skill-sets Desired

Computer Engineering	Project Management
Mechanical Engineering	Electrical Engineering
Technical Writing	Marketing/Public Relations
Aerospace Engineering	Business Management

Project Management

Budget

Table 3: Project Budget delivers a breakdown of the different Systems in terms of monetary costs. Quality of components is the driver of this Budget, as this Project would suffer greatly with inferior materials.

Table 3: Project Budget

System	Amount
Vehicle	\$889.95
Test-Stand	\$881.72
Remote Control Unit (RCU)	\$265.55
Ground Control Station (GCS)	\$153.75
Total:	\$2190.97

Team Coordination

As the two primary team members of this project are separated geographically, collaboration has been a necessity for the continued engineering effort of this project. Several common and freely available tools have been used in this regard.

-Google Doc's:

Documentation that needs to be current, dynamic, accessible and editable by several users is maintained on the Team's Google Doc's folder. Specifically, the Team's Action Item List, Meeting Agendas and others are hosted on Google Doc's.

-SVN

Subversion (SVN) software, originally used to maintain current revisions of source code for projects has been used extensively in this project, not only with the three different programming variants (C, SPIN and Labview) but is also used for document version control as well. This tool ensures that all files that can't be controlled through Google Doc's are still maintained at the correct version.

-Project Wiki

A tool for advertising and limited collaboration, the Project Wiki page is a tool to display the project and give links to the public to view the current Project status, along with explanations of files, distribute compiled code and so on.

Project Schedule

To facilitate development, this Project has been split into distinct Phases to provide a foundation of learning at each Phase and discernible Milestones upon each transition to the following Phase.

Phase Schedule

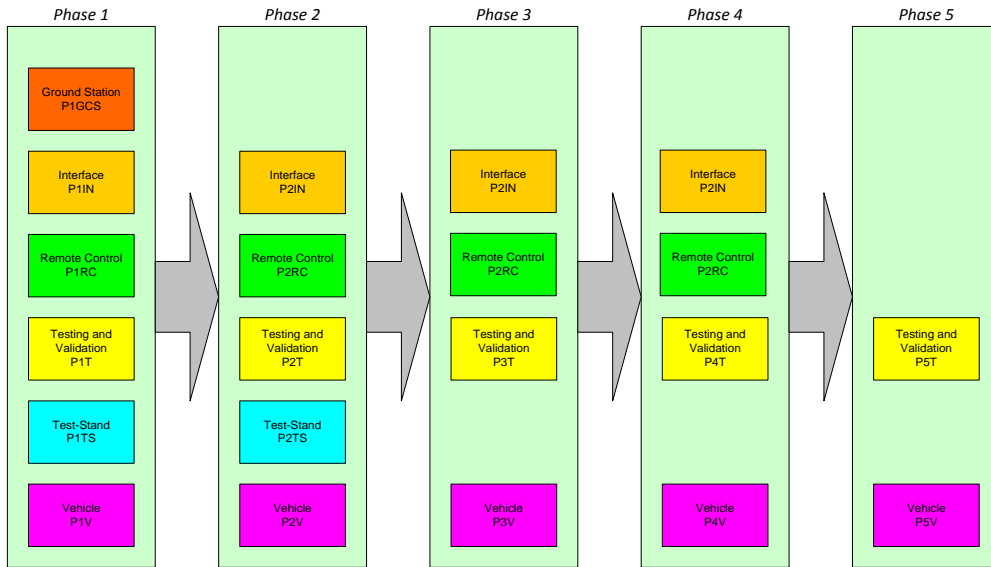

Figure 1: Project Phase Plan

Phase 1:

Program Objective(s):

Vehicle:

Design and Build Vehicle

RCU:

Design, Build and Program for S/W ver 1.0 functionality

Test-Stand:

Design and Build Test Stand

GCS:

Design and Build GCS

GCS Interface:

Program for S/W ver 1.0 functionality

Ancillary Objective(s):

- Create Initial System and Subsystem Documentation.
- Design and Deploy Communications Network.
- Implement development environment for Primary Controller.
- Implement Program Wiki Page.

Engineering Challenges:

Design and Implement the RF Communications system to be able to handle the required data rate with a reliable Quality of Service (QoS) at sufficient distances.

Phase 2:

Program Objective(s):

- Vehicle: Program for S/W ver 1.0 functionality
- RCU: Program for S/W ver 2.0 functionality
- GCS: Program for S/W ver 2.0 functionality
- Test Stand: Build Test Fixture Assembly and electronics

Engineering Challenges:

Design and Implement Discrete PID Control on Secondary Controller. Design and Implement Kalman Filter on Secondary Controller.

Design and Implement an appropriate DSP algorithm (using Kalman Filter, Complimentary Filter, or equivalent) for Primary-INU.

Phase 3:

Program Objective:

- Vehicle: Program for S/W ver 2.0 functionality
- RCU: Program for S/W ver 3.0 functionality
- GCS: Program for S/W ver 3.0 functionality

Engineering Challenge: Design an advanced Control System on Vehicle to increase Vehicle stability and responsiveness.

Phase 4:

Program Objective:

- Vehicle: Program for S/W ver 3.0 functionality
- RCU: Program for S/W ver 4.0 functionality
- GCS: Program for S/W ver 4.0 functionality

Phase 5:

Program Objective:

- Vehicle: Program for S/W ver 4.0 functionality

Engineering

Design Challenges

Communications

Wireless Network Link:

The Vehicle, Ground Control Station (GCS) and Remote Control Unit (RCU) communicate using an XBee API wireless Network. The API implementation gives the benefit of individually addressing different Systems on the Network. This allows different scenarios to exist, such as using RCU to manually fly the Vehicle and showing the Vehicle's flight path on the Interface, piloting the Vehicle through the Interface and displaying Error codes on the RCU, and even extending the range of the Vehicle by placing the RCU in between the Interface and Vehicle.

For a model of the Signal-To-Noise Ratio based on distance, see Appendix ~~XX~~: SNR Model

For a diagram of the Communications Link, see Figure 2: Communication Link Diagram.

Comment [DPG5]:

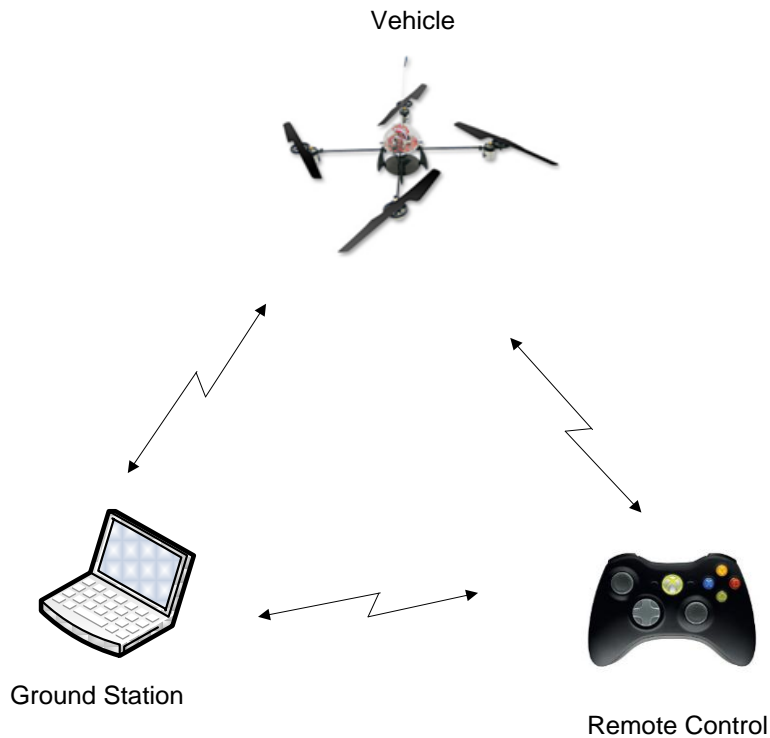

Figure 2: Communication Link Diagram

Communications Protocol

A Communications Protocol (See Appendix **XX**: Robo-Chopper Communications Protocol) has been developed to facilitate communications on the Network and in the case of the Vehicle, to communicate between the different Controllers. While not strictly optimized, the Protocol has been designed to increase User readability while requiring low throughput requirements. Additionally, error detection has been incorporated into the Project. Each data packet (See Figure 3: Data Packet Detail) includes a message number to add in handling missed transmissions, a checksum that is calculated using the addition of each byte value of a data packet and then inserting that value at the end of the data packet before transmission. At the receiving end, the data packet again goes through this addition process and if the calculated checksum and the transmitted checksum do not match, the data packet is treated as garbage and thrown away. Some message types are programmed for re-transmission if deemed necessary but are reduced as much as possible as this would result in longer delay between receiving following data packets.

Comment [DPG6]:

Comment [DPG7]:

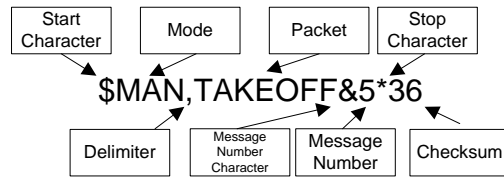

Figure 3: Data Packet Detail

See Box 1 and Box 2 for an example of the Robo-Chopper Communications Protocol.

SEN: Sensor Data
 \$SEN,<Sensor Type>,<Value 1>|<Value 2>, ...<Value n>*
 -Sensor Types:
 "ACC": Value 1 - x axis, Value 2 - y axis, Value 3 - z axis, in meters/second^2.
 \$SEN,ACC,+0000,+1111,+2222*

Box 1: Sensor Data Communications

MAN: Manual Control
 \$MAN,<Device>,<Value 1>|<Value 2>...<Value n>*
 -Device:
 "THROTTLE", where Value 1 is a PWM value from 0-255.
 \$MAN,THROTTLE, 255*

Box 2: Motor Command Communications

The Wireless Network works in a manner similar to addressable wireless serial devices. To maximize the range of the Network while ensuring appropriate data throughput, the minimum (standard) baud rate of the Network was determined (See Table 4: Minimum Baud Rate Calculations) to be 9600 bits per second bits.

Table 4: Minimum Baud Rate Calculations

<i>Data Packet Method</i>	<i>Packet Length (Max bytes)</i>	<i>Required Update Time (mSec) / hz</i>	<i>Required Minimum Bit Rate (bps) [1]</i>
Manual Control Packets	24	20 ms/ 50 hz	9600 bps
Auto Control Packets	29	50 ms/ 20 hz	4640 bps

Notes: [1] Minimum Bit Rate = Packet Length*8*1000/Required Update Time (mSec)

Network Initialization:

When any device is added onto the network, it will broadcast a continuous NCK packet. When another device picks up this NCK packet, it will start a 3-way handshake, as illustrated in Figure 4: 3-Way Handshake. This process will work in a similar manner in API mode, with the exception that when the 3-way handshake is initiated it will proceed with individually addressed nodes instead of broadcast.

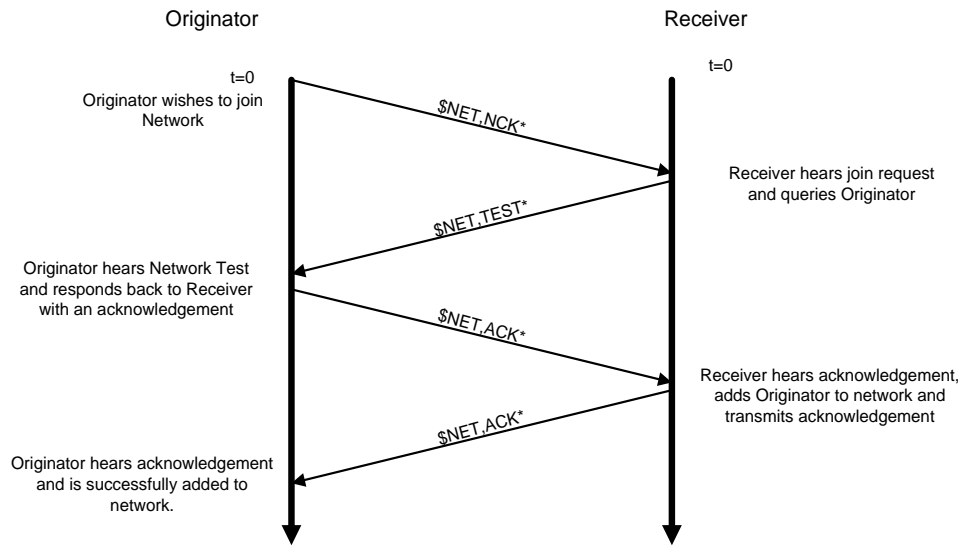

Figure 4: 3-Way Handshake

Multiple-Controller Implementation

Since the Vehicle will have a Primary and Secondary controller, it may become necessary during development, debugging and even operation for the Vehicle to be controlled by the Primary and Secondary Controller together or the Secondary Controller alone. For this reason, the radio has been connected to multiplexers that are controlled by the Secondary Controller, as the Primary Controller will have no facilities to control the Vehicle by itself. The user may request the Secondary Controller to take commands from the Primary Controller or to act as the Primary Controller, controlling the Vehicle directly. The advantages of this approach allow simpler operation of the Vehicle via the Secondary Controller as it provides direct control of the motor drivers, at the expense of the Primary-INU and autonomous navigation.

Flight Power Capabilities

Lift Calculations:

The Lift produced by the Vehicle's propellers is very important to calculate, as this will dictate the amount of additional elements weigh. The study of the Lift produced is an empirical calculation as there are many variables that are not readily known. At best, before the Vehicle is capable of being experimentally verified, a range of calculations should be performed.

The Lift equation for a rotating airfoil is [1]:

Comment [DPG8]:

$$L = .5\rho v^2 A C_L$$

$$L: \text{Lift } \frac{\text{kg} \cdot \text{m}}{\text{s}^2}$$

ρ : Atmospheric Density,

ρ can range from 1.2 (dry Air at Sea Level) to 1.2041 at 20° C (68° F)

A: Area of rotor .006 m^2

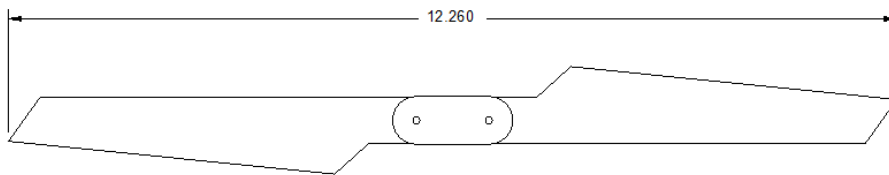

Figure 5: Vehicle Rotor Diagram

C_L : Coefficient of Lift. Assumed to be 1, until experimentally calculated.

v : Velocity of airfoil moving in the air. Since the lift calculation is normally applied for an airplane wing the velocity of the wing can be measured at a constant velocity. However, the only lift produced on a quad-rotor helicopter is produced by the rotating propeller, and as such the velocity of the airfoil varies across the length of the blade. The lift calculation has been calculated at various rpm's of the rotors, and at various distances along the rotor blade.

$$v = r_L \cdot \omega$$

Each rotor is geared down to increase torque.
Gear ratio: $56/10 = 5.6$

From Motor Datasheet [3]:

Comment [DPG9]:

At maximum motor efficiency:

$$\omega_{EFF} = 13790 \text{ rpm} / (60 * 5.6) = 41.1 \text{ rev/sec}$$

At maximum motor speed:

$$\omega_{MAX} = 16500 \text{ rpm} / (60 * 5.6) = 49.1 \text{ rev/sec}$$

At 75% of maximum motor speed:

$$\omega_{75} = 12375 \text{ rpm} / (60 * 5.6) = 36.8 \text{ rev/sec}$$

After experimentation the real lift may be determined, but until then the lift calculations are performed using a best guess for the different parameters.

Table 5: Lift Force Calculations

	ω_{EFF}	ω_{MAX}	ω_{75}
At rotor wingtip	Lift (pounds)	Lift (pounds)	Lift (pounds)
100%	3.07	4.37	2.46
90%	2.48	3.54	1.99
75%	1.72	2.46	1.38
50%	0.77	1.09	0.61

Control Algorithm

Overview:

As the Vehicle is a highly dynamic system, and coupled with performing flying operations in an outdoor environment, Control of its position and movement is a paramount concern. 2 models of the Control Algorithm have been developed.

The Phase 2 Control Algorithm (See Figure 6: Phase 2 Control System) deals with the Primary Controller performing all the INU work by computing the necessary Kinematic Equations. Angle commands are

sent to the Secondary Controller (See Figure 7: Phase 2 Secondary Controller Block Diagram) where they are immediately processed and the appropriate Motor commands are sent to the Electronic Speed Controllers, which in turn drive the rotor motors.

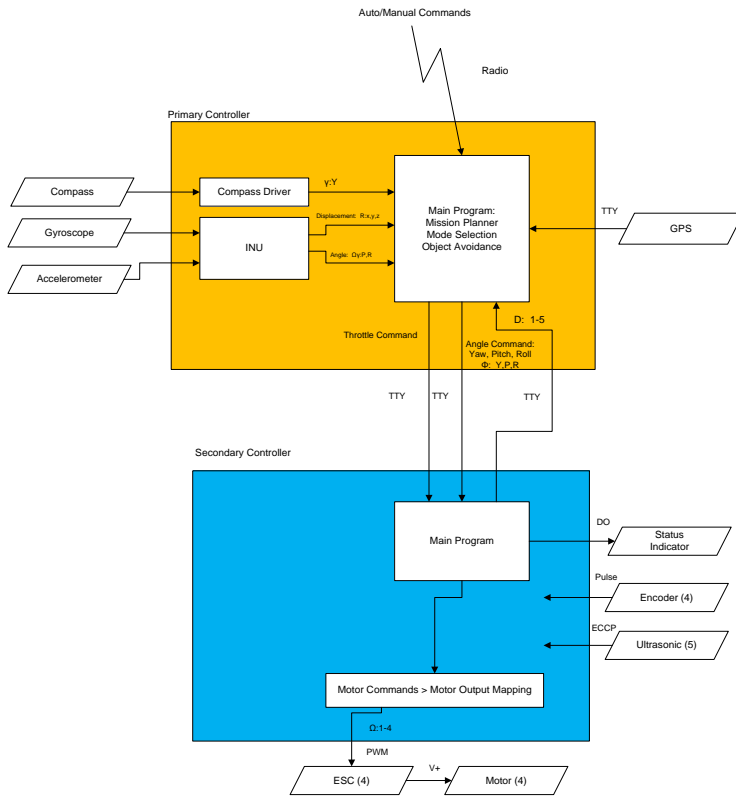

Figure 6: Phase 2 Control System

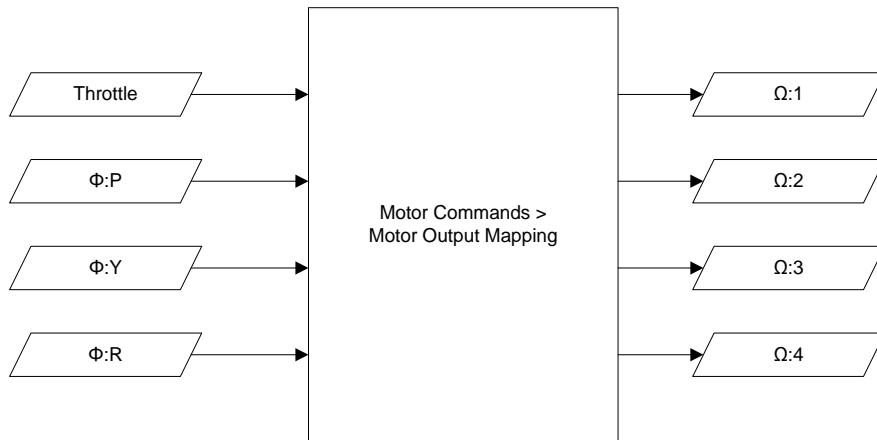

Figure 7: Phase 2 Secondary Controller Block Diagram

The Phase 3 Control Algorithm (See Figure 8: Phase 3 Control System) is a more intelligent control algorithm. Besides the basic kinematic equations calculated on the Primary Controller, sensor data is also fed into a Kalman Filter on the Secondary Controller. This allows the Primary Controller to deal more with higher level tasks, such as Object Avoidance and Mission Planning (Figure 9: Phase 3 Primary Controller Block Diagram) , and increases stability of the Vehicle through the Kalman Filter and PID Control on the Secondary Controller (Figure 10: Phase 3 Secondary Controller Block Diagram).

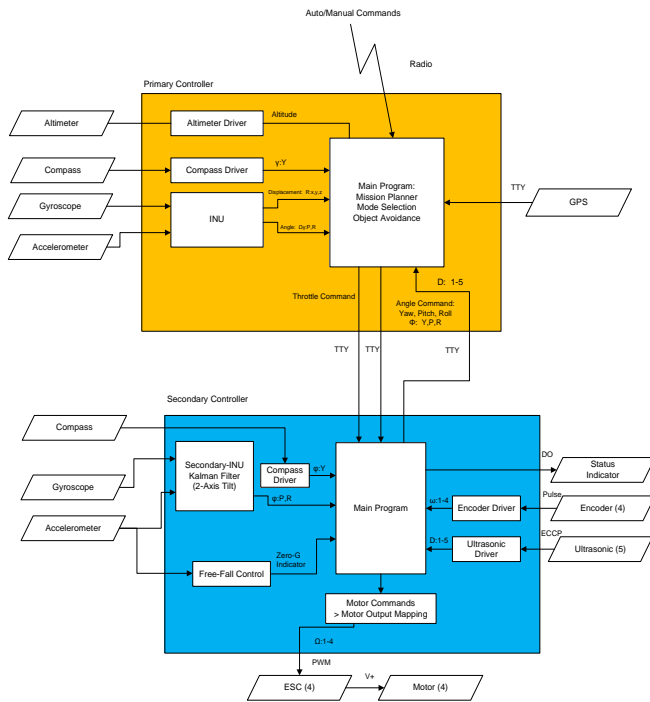

Figure 8: Phase 3 Control System

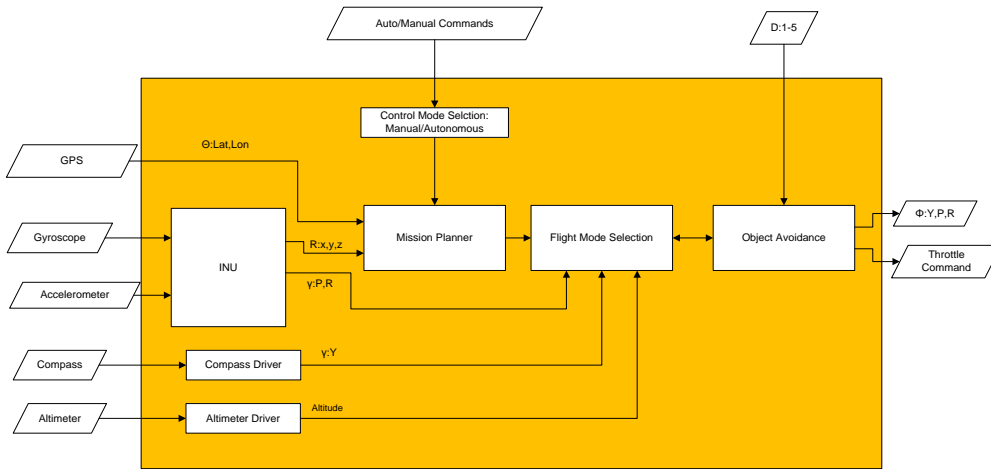

Figure 9: Phase 3 Primary Controller Block Diagram

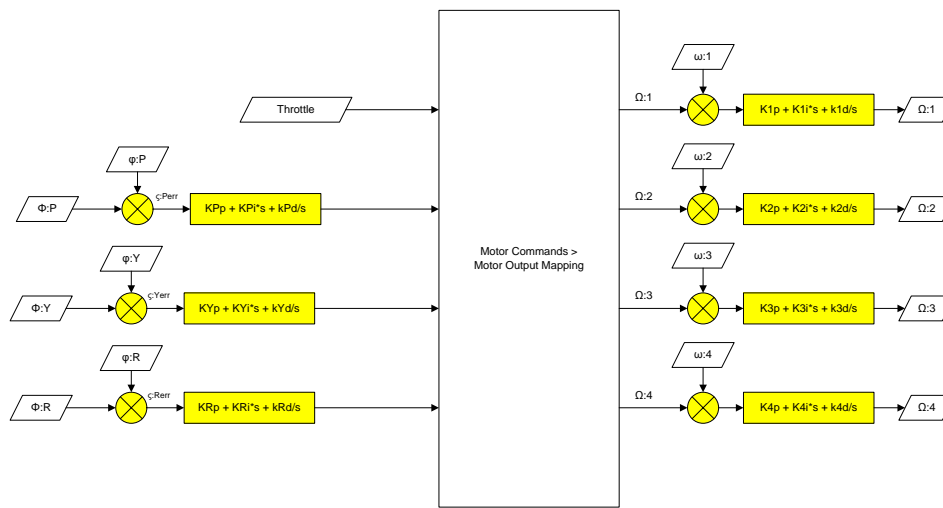

Figure 10: Phase 3 Secondary Controller Block Diagram

Design:

INU

The Inertial Navigation Unit (INU) is comprised of a 3-Axis Accelerometer and a 3-Axis Gyroscope. Due to the properties of the sensors, digital filters are needed to decrease the amount of noise on each sensor measurement. See Appendix XX: Filter Design for the digital filters implemented on the Primary Controller. After the sensor data is filtered appropriately, it is fed into a series of Kinematic Equations

Comment [DPG10]:

(See Appendix XX: INU Design) and the resultant output (See Figure 11: INU Diagram) is a 6 element vector containing the 3 variables that represent the Vehicle's displacement in the 3 Cartesian axis's, and 3 variables that represent the Vehicle's rotational displacement in the spherical coordinate system.

Comment [DPG11]:

Gyro Sensor

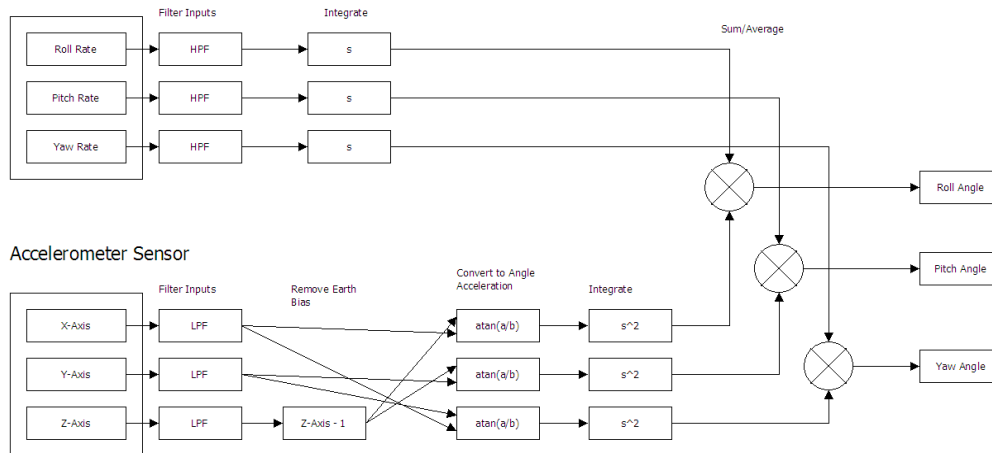

Figure 11: INU Diagram

However, since discrete summation is a necessary part of the Kinematic Equations, error can build up quickly. The INU data is only used in between GPS location signals. As the GPS sensor selected outputs location data at approximately 4Hz, the INU is reset at 4Hz.

Comment [DPG12]: Diagram is obsolete

Test Plans

A Test Plan that continues through the different Phases of the Project has been developed. Its purpose is to perform validation of engineering work by verifying the design of the System at critical periods during the design and build process. See Appendix: XX Test Plans for an explanation and procedure for each Test Plan.

Test Plan Phase Purposes:

Phase 1: Validate the communication network range and reliability of the XBee network.

Phase 2: Validate the design of the Vehicle, along with verification of the lift characteristics of the Vehicle.

Phase 1 Test Plan

Objective 1: Initial Test of Radio Communications

Test 1: Dropped Packet Measurement

Configuration:

- 2-Node XBee Network
- XBee and GPS connected to Propeller on Remote Node.
- Matlab program running on laptop.
- Remote Node has no loopback installed.
- Transmit to Coordinator location,sequence number for each packet.

Matlab program acquiring Remote Node packets, and logging the time that they actually arrived.

Measurements:

- Rough quantitative analysis of Range
- Qualative analysis of Data Throughput
- Qualative analysis of Node Reliability

Method:

Continually transmit dummy packet from Coordinator to Remote Node with MatLab. Remote Node responds back with Location,sequence number in the following manner:

\$RSSI,latitude,longitude,seq_number*

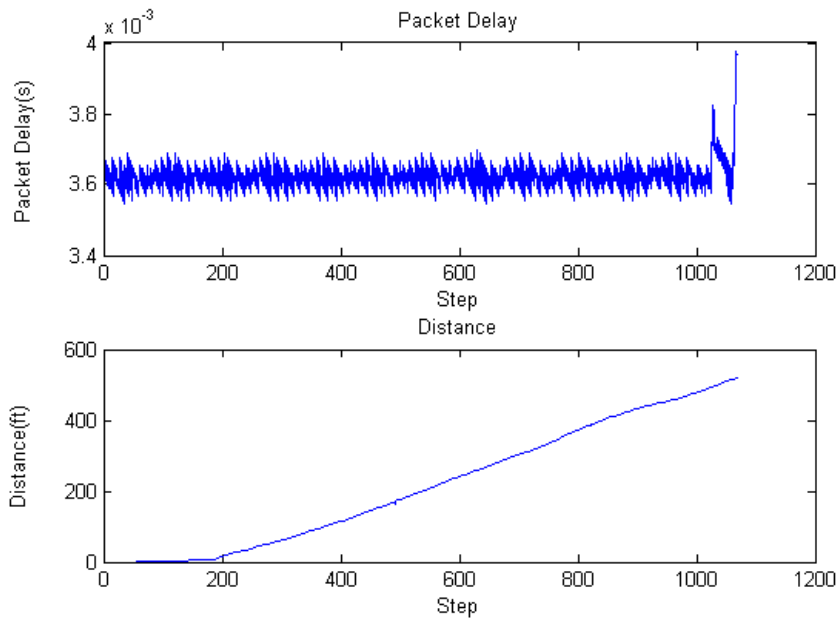

Figure 12: 9600 Baud w/ High Antenna

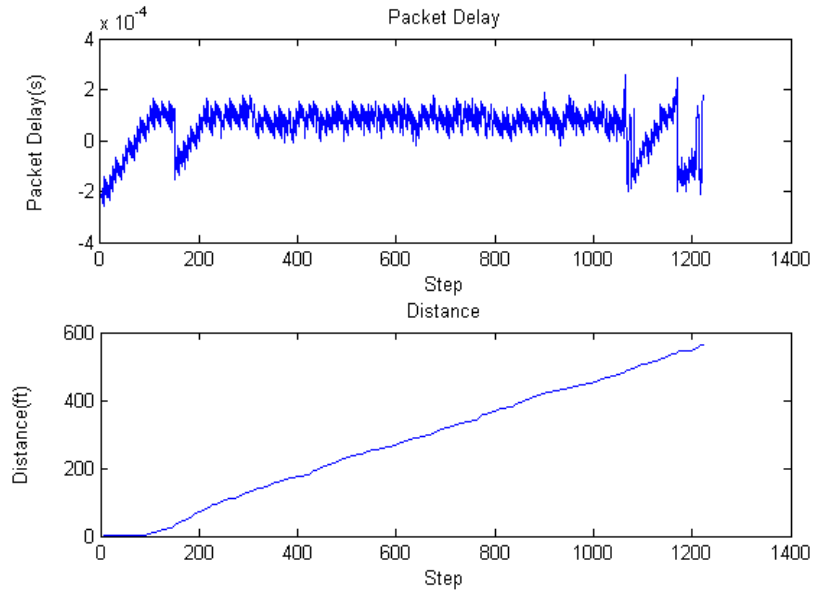

Figure 13: 115200 Baud w/ High Antenna

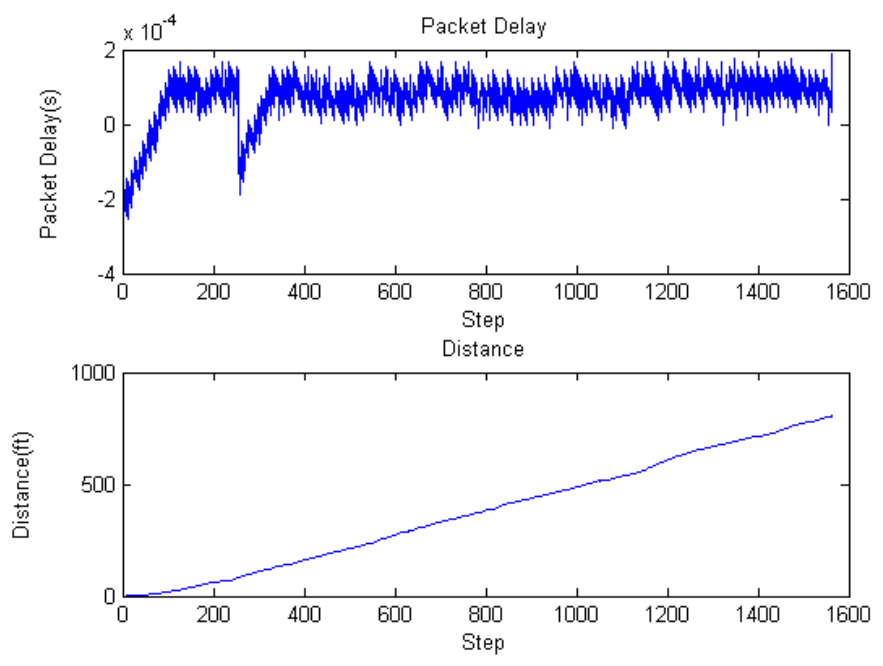

Figure 14: 115200 Baud w/ Low Antenna

Table 6: Dropped Packet Measurement Results

	9600 Baud w/ High Antenna	115200 Baud w/ High Antenna	115200 Baud w/ Low Antenna
Maximum Distance Recorded (ft):	519.1 ft	564.0 ft	805.5 ft

Phase 2 Test Plan

Objective 1: Evaluate Flight Power Characteristics.

Test 1: Baseline Measurements w/ Fixed Power Supply

Configuration:

Vehicle:

- Task P2V is sufficiently complete to allow basic flight tests.
- Power Supply: Fixed AC Power Supply, optional: Ability to log Voltage/Current from Supply.

Test Stand:

- Task P1TS and P2TS1 are complete.
- Counterweight offset to everything except Robo-Chopper weight.

Necessary Equipment:

- Strobe Timing Light

Measurements:

- Determine Maximum Thrust, i.e. Thrust Force with Motor RPM at Maximum Throttle.
- Determine Motor RPM at Nominal Thrust, i.e. Motor RPM at Thrust Force = Robo-Chopper weight.

Test 2: Baseline Measurements w/ Battery Power Supply

Configuration:

Vehicle:

- Same as in Test 1, except Power is derived from on-board battery(ies).

Test Stand:

- Same as in Test 1.

Necessary Equipment:

- Same as Test 1.

Measurements:

- Same as Test 1, plus:
- Set Motors to Max RPM, log Thrust data.
- Set Motors to 1/2 Max RPM, log Thrust data.
- Repeat above 2 lines 3 times each for 2 Series of Tests, 1 with 1 Battery, 1 with 2 Batteries.

Results:

- Determine Experimental Thrust/Weight Ratio: Goal is 2:1.
- Determine Max Takeoff Weight, Add-on Weight, etc.
- Determine experimental friction coefficients in Test Stand.

- Determine approximate Flight Times with different Mission Profiles.
- Develop Mission Profiles/Robo-Chopper Design to enhance Flight Time.
- Determine Trends in Power vs. Time for different Mission Profiles.

System-Vehicle

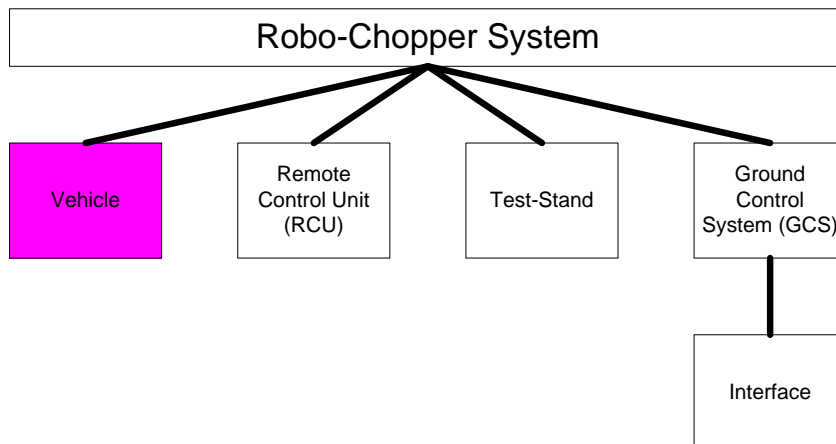

Summary

The Vehicle is a Quad-Rotor Helicopter that is capable of Manual and Autonomous flight. It weighs approximately X pounds, is capable of flying for up to X minutes with a top speed of X feet per second. It is able to take off, hover and land automatically, and navigate to waypoints as well. See Figure 15: Vehicle Picture for a picture of the Vehicle in its current condition and Figure 16: Vehicle CAD Diagram for the design of the Vehicle.



Figure 15: Vehicle Picture

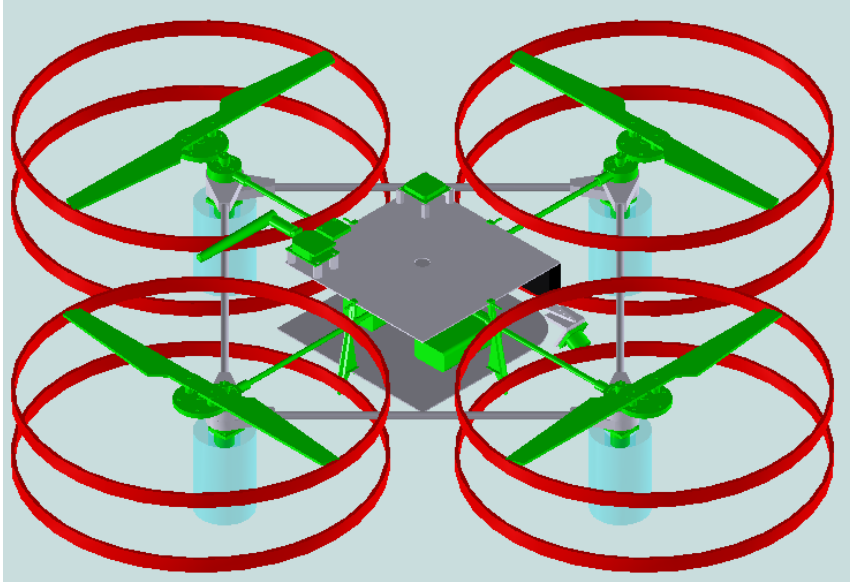

Figure 16: Vehicle CAD Diagram

Figure - Vehicle Block Diagram

Comment [DPG13]:

Figure - Vehicle Block Diagram

Comment [DPG14]:

Figure – Vehicle Block Diagram

Comment [DPG15]:

The Vehicle has been divided into 2 sections (See Figure 17: Vehicle System Responsibility Diagram), one controlled by the Primary Controller, and one controlled by the Secondary Controller.

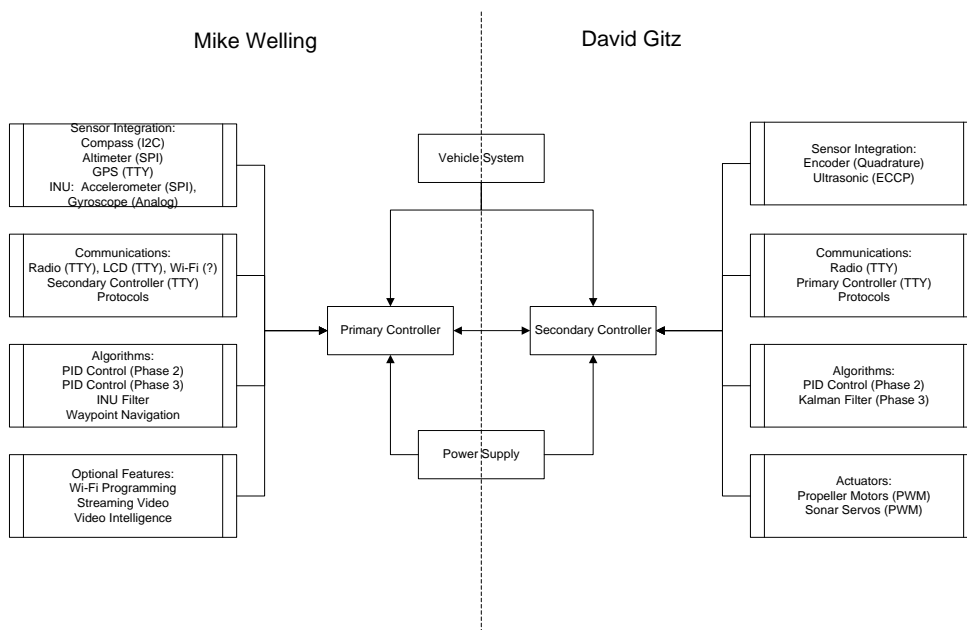

Figure 17: Vehicle System Responsibility Diagram

Budget

Table 7: Vehicle Budget

Subsystem	Amount
Frame	
Sensors	
Power	
Control Board	
Total:	

Action Item List

Table 8: Vehicle Action Item List

P1V	Vehicle
P1V1	Develop Conceptual Documents/Subsystem Documents
P1V2	Design Initial Circuit Board
P1V2-A	Select/Source Primary Controller
P1V2-B	Develop Initial Program on Primary Controller
P1V2-C	Develop Initial Program on Secondary Controller
P1V2-D	Integrate Communications on Secondary Controller
P1V2-E	Implement Mockup PCB for Phase 1 Test Plan
P1V2-F	Create BOM for PCB
P1V3	Perform Circuit Design Analysis
P2V	Vehicle
P2V1	Design Circuit Board
P2V1-A	Integrate Communications on Primary Controller
P2V1-B	Integrate Sensors on Primary Controller
P2V1-C	Integrate Sensors on Secondary Controller
P2V1-D	Incorporate design changes onto PCB Design
P2V1-E	Validate PCB Design
P2V2	Order Parts
P2V3	Fabricate Circuit Board
P2V4	Assemble Vehicle
P2V5	Develop Control System for Primary-INU
P2V6	Develop Program on Primary Controller
P2V7	Develop Program on Secondary Controller
P3V	Vehicle
P3V1	Develop advanced Control System
P3V1-A	Derive description and roadmap for integration
P3V1-B	Derive Control equations for Primary Controller
P3V1-C	Derive Control equations for Secondary Controller

Subsystem – Sensors

Overview

The Sensors Sub-System consists of many sensors, including: A Gyroscope, Accelerometer, GPS, Compass, Altimeter, Quadrature Encoders and Ultrasonic sensors. An Inertial Navigation Unit (INU) is implemented by fusing the Accelerometer and Gyroscope data and utilizing the appropriate inverse-kinematic equations the position of the Vehicle can be found.

Table 9: Sensor Measurement Comparison

Measurement: Sensor:	Inertial Rotation	Inertial Acceleration	Ground Position	Ground Velocity	Heading	Altitude above Sea Level	Altitude above Ground	Mechanical Rotation	Distance to Object
Gyroscope	X								
Accelerometer		X							
GPS			X	X	X	X			
Compass					X				
Altimeter							X		
Quadrature Encoder								X	
Ultrasonic									X

Component Selection and Specifications:

Table 10: Gyroscope Selection Matrix

Specification	Minimum Requirement	Gyroscope SEN-09093	Gyroscope SEN-09422	Gyroscope SEN-09801
# of measurement Axis's	2	2	2	3
Temp Sensor		On-Chip	None	On-Chip
Sensitivity		15mV/deg/sec	8.3 mV/deg/sec; 33.3 mV/deg/sec	

Rate		+/- 67 deg/sec	+/-120 deg/sec; +/- 30 deg/sec	+/- 1200 deg/sec
Comm Protocol		Analog	Analog	I2C
Input Voltage	3-5 Volts	3-7 Volts	2.7 – 3.6 Volts	2.1 – 3.6V
Current Draw		10 mA	7 mA	7 mA
Size		2.7 in^2	2.7 in^2	.7" x .55"
Price		\$39.95	29.95	49.95
Other Features		On-board LPF	1x/4x Output; On-board LPF; Self-Test	On-Board LPF
Vendor		Spark Fun	Spark Fun	Spark Fun
Website		Link	Link	Link

Table 11: Accelerometer Selection Matrix

Specification	Minimum Requirement	Accelerometer 28026	Accelerometer SEN-09269	Accelerometer SEN-00252
# of measurement Axis's	3	3	3	3
Measurement Range	+/- 2 g	+/- 3 g	+/- 3 g	+/- 1.5 g; +/- 2 g; +/- 4 g; +/- 6 g
Sensitivity		366.3 mV/g	300 mV/g	800 mV/g; 600 mV/g; 300 mV/g; 200 mV/g
Accuracy		10%	1%	5%
Comm Protocol		SPI	Analog	Analog
Input Voltage		4.5 – 5.5 Volts	1.8 – 3.6 Volts	2.2 – 3.6 Volts
Current Draw		10 mA	.35 mA	.5 mA
Size		.56 in^2	.49 in^2	.64 in^2
Price		34.99	24.99	19.99
Other Features		Zero-G Voltage Output	On-Board LPF	On-Board LPF
Vendor		Parallax	Spark Fun	Spark Fun
Website		Link	Link	Link

Table 12: Altimeter Selection Matrix

Specification	Minimum Requirement	Altimeter SEN-08161		
Measurement Range		30 – 120 kPa		
Resolution		1.5 Pa		
Refresh Rate		1.8 Hz/9 Hz		
Comm Protocol		SPI		
Input Voltage		2.4 – 3.3 Volts		
Current Draw		25 uA		
Size		.56 in^2		
Price		34.95		

Other Features		High Resolution Mode/High Speed Mode		
Vendor		Spark Fun		
Website		Link		

Notes:

1. No other distributor for an Altimeter has been sourced.

Table 13: Compass Selection Matrix

<i>Specification</i>	<i>Minimum Requirement</i>	<i>Compass SEN-07915</i>		
Resolution		.5 Deg		
Repeatability		1 Deg		
Refresh Rate		1 – 20 Hz		
Field Range		.75 Gauss		
Comm Protocol		I2C		
Input Voltage		2.7 – 5.2 Volts		
Current Draw		10 mA		
Size		1.5 in^2		
Price		34.95		
Other Features				
Vendor		Spark Fun		
Website		Link		

Notes:

1. Parallax also offers an electronic compass but uses the same sensor part number as the item selected from Spark Fun.

Table 14: Ultrasonic Selection Matrix

<i>Specification</i>	<i>Minimum Requirement</i>	<i>Ultrasonic SEN-08503</i>	<i>Ultrasonic 28015</i>	
Refresh Rate		20 Hz	50 Hz	
Resolution		1 inch		
Range		6 – 254 in	1 – 118 in	
Operating frequency		42 kHz	40 kHz	
Comm Protocol		Analog, Serial, PWM	ECCP	
Input Voltage		2.5 – 5.5 Volts	5 Volts	
Current Draw		2 mA	35 mA	
Size		.69 in^2	1.5 in^2	
Price		27.95	29.99	
Other Features		Multiple comm protocols		
Vendor		Spark Fun	Parallax	
Website		Link	Link	

Table 15: GPS Selection Matrix

Specification	Minimum Requirement	GPS GPS-08975	GPS SEN-00465	GPS GPS-08621
Refresh Rate	1 Hz	5 Hz	N/A	N/A
Channels	12	32	20	20
Position accuracy		3 meters	10 meters	10 meters
Sensitivity		N/A	-159 dBm	-3.5 dB
Comm Protocol	Serial - NMEA	Serial - NMEA	Serial - NMEA	Serial - NMEA
Input Voltage		3.3 Volts	4.5 – 6.5 Volts	3.1 – 3.5 Volts
Current Draw		41 mA	44 mA	82 mA
Size		1.5 in^2	1.2 in^2	5 in^2
Price		59.95	59.95	89.95
Other Features		LED Fix Indicator, WAAS, battery backup	LED Fix Indicator, GPS Time Sync output, battery backup	Helical Antenna, GPS Time Sync output, battery backup
Vendor		Spark Fun	Spark Fun	Spark Fun
Website		Link	Link	Link

Table 16: Encoder Selection Matrix

Specification	Minimum Requirement	Encoder AM-0714		
Encoder Type	Incremental	Incremental		
# of Positions/Revolution		250		
Maximum RPM	3,000	10,000		
Shaft Size		.059 - .250 "		
Comm Protocol		Quadrature Pulse		
Input Voltage		5 Volts		
Current Draw		18 mA		
Size		.57 in^2		
Price		25.25		
Other Features				
Vendor		AndyMark		
Website		Link		

Notes:

1. Maximum RPM Minimum requirement is calculated from the following:
Maximum motor RPM / Propeller gear ratio = 16,500 RPM / 5.5 = 3,000 RPM

Subsystem – Power

Overview

The Vehicle is powered by 2 Lithium-Ion rechargeable batteries operating at 11.1 V. On the control Board, reverse voltage protection is designed so that one battery may not discharge into the other. As the Lithium-Ion battery chemistry is marginally unstable, charging and dis-charging must be done according to the battery’s specifications. Accordingly, a special charger must be used to charge the batteries, and the maximum current discharge rate of the batteries must not be exceeded. Li-Ion batteries offer the benefit of a smaller size/weight with increased capacity and increased discharge rate than the Nickel-Metal Hydride and Nickel-Cadmium battery chemistries. ref

Comment [DPG16]:

From the batteries, power is supplied to the Control Board and to Electronic Speed Controller’s (ESC’s) that power the rotors based on the signals provided from the Control Board. ESC’s utilize a Pulse-Width Modulated Signal that drives a H-Bridge circuit in each ESC, which amplifies the voltage and current to the rotors. Opticalisolation is also provided in the Control Board to reduce the amount of Electro-Magnetic Interference (EMI) caused by the rotors, using opto-isolator Integrated Circuits (ICs).

Component Selection and Specifications:

Table 17: Battery Selection Matrix

<i>Specification</i>	<i>Minimum Requirement</i>	<i>DF-BATT1350-BALANCE</i>	<i>TP-2100-3SPL2</i>	
Chemistry	Li-Ion	Li-Ion	Li-Ion	
Nominal Voltage		11.1 V (3 cells)	11.1 (3 cells)	
Charge/Discharge Cycles		150		
Continuous Discharge		27A	42A	
Capacity		1350 mAh	2100 mAh	
Size		19 x 34 x 65 mm	21 x 35 x 103 mm	
Weight		86 grams	147 grams	
Price		59.95	\$47.99	
Other Features		Balance Connector, Wired Connectors,OEM	Balance Connector	
Vendor		RC Toys	RC Toys	
Website		Link	Link	

Battery Charger

Comment [DPG17]:

Table 18: Electronic Speed Controller Selection Matrix

<i>Specification</i>	<i>Minimum Requirement</i>	<i>ESC EFLA106</i>	<i>ESC BB-1245</i>	<i>ESC GPMGPMM2005</i>
Type	Brushed		Brushed	Brushed
Input Voltage		6-12 V	6 – 24 V	11.1 V
Max Continuous Current	5 A	30 A	12 A	7 A
Peak Current	10 A		45 A	?
Bi-Directional?		No	Yes	N
Weight		.86 oz		.2 oz
Price		\$49.99	\$57.00	19.99
Other Features		BEC, designed for A/C, Thermal overload, prewired with connectors	Direction indicators, Thermal overload	BEC,audible tones for setup
Vendor		Advantage Hobby	Bane Bots	Advantage Hobby
Website		Link	Link	Link

Subsystem – Frame

Overview

The Frame is an important consideration of a Quad-Rotor Vehicle. Obviously strength and weight are very important factors, as are cost, vibration absorption and structural mounting points. The Original Equipment Manufactured (OEM) frame is constructed with plastic mounts and carbon-fiber tubes, and is very light. However, to increase the lifetime and structural support of the Vehicle, additional pieces have been constructed to enhance the rigidity of the frame with a small increase in weight and cost.

Figure

Comment [DPG18]: OEM/New Design

Component Selection and Specifications:

Frame

Comment [DPG19]:

Table 19: Motor Selection Matrix

<i>Specification</i>	<i>Minimum Requirement</i>	<i>Motor (w/ 1:5.6 OEM ratio)</i>	<i>Motor</i>	
Motor Type	Brushed	RK-370SD-2870	Brushed	
Operating Voltage		4.5 – 9.6V	7.2 V	
No Load Speed		2946 rpm		
No Load Current		.34 A		
Stall Torque		28.78 oz in		

Stall Current		8.77A	10 – 25 A	
Maximum Efficiency Speed		2462.5 rpm		
Maximum Efficiency Current		1.73 A		
Maximum Efficiency Torque		4.732 oz in		
Maximum Efficiency Power		8.61 W	45 – 170 W	
Power/Weight Ratio		4.81 W/oz		
Shaft Diameter		2 mm	3.2 mm/1/8"	
Shaft Length		10.3 mm		
Weight		1.79 oz	3.5 oz	
Diameter		24.4 mm	29.1 mm	
Motor Length		30.8 mm	1.875"	
Gear Pitch				
Price			\$28.99 ea	
Other Features		OEM		
Vendor			Hobby Lobby	
Website		Link	Link	

Table 20: Propeller Selection Matrix

<i>Specification</i>	<i>Minimum Requirement</i>	<i>Propeller DF-1245CR</i>		
Length		12 in		
Pitch		4.5 in/rev		
Material		Composite		
Shaft size		3 mm		
Price		\$5.95		
Other Features		Includes one CW and one CCW blade		
Vendor		RC Toys		
Website		Link		

Subsystem – Control Board

Overview

Component Selection and Specifications:

Primary Controller

Secondary Controller

Voltage Regulation

Subsystem – Communications

Overview

Component Selection and Specifications:

Table 21: Radio Selection Matrix

Specification	Minimum Requirement	Radio WRL-08768	Radio WRL-09411	
Type		XBee	XBee	
Range		1 mile	40 miles	
Operating Frequency		2.4 GHz	900 MHz	
Output		50 mW/17dBm	1 W/30 dBm	
Comm Protocol	Serial	Serial	Serial	
IEEE Protocol		802.15.4	N/A	
Data Throughput				
Input Voltage		3.3V	5V	
Current Draw		295 mA	730 mA	
Size		2 in ²	4 in ²	
Price		44.95	\$184.95	
Other Features		Mesh Network capable	Mesh Network capable, uses FHSS, maximum power legally available	
Vendor		Spark Fun	Spark Fun	
Website		Link	Link	

System - Remote Control Unit (RCU)

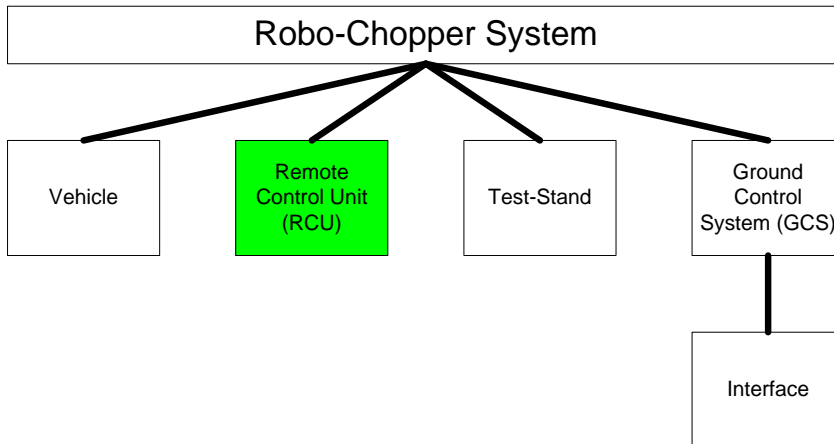

Summary

A Remote Control has been designed to manually control the Vehicle. It is comprised of a modified Xbox-360 Wireless Game Controller. It also provides a means of feedback to the User of any error messages that occur on the System, along with limited flight mode control. See Appendix XX: "Remote Control Design Report" for more information.

Comment [DPG20]:

Budget

Table 22: RCU Budget

<i>Subsystem</i>	<i>Amount</i>
Control Board	\$400.63
Total:	\$400.63

Action Item List

Table 23: RCU Action Item List

P1RC	Remote Control
P1RC1	Design Circuit Board
P1RC1-A	Component Footprints
P1RC1-B	Verify Circuit Board Design on Proto-Board
P1RC2	Order Parts
P1RC3	Fabricate Circuit Board
P1RC4	Develop MicroController Program ver 1.0
P1RC5	Validate MicroController Program ver 1.0
P1RC6	Analyze Fabricated Circuit Board Design
P1RC7	Design Network Init/Network Test Process
P1RC7-A	Perform RF Engineering
P1RC8	Assemble Remote Control
P2RC	Remote Control
P2RC1	Develop Microcontroller Program ver 2.0
P2RC2	Validate Microcontroller Program ver 2.0
P3RC	Remote Control
P3RC1	Develop Microcontroller Program ver 3.0
P3RC2	Validate Microcontroller Program ver 3.0
P4RC	Remote Control
P4RC1	Develop Microcontroller Program ver 4.0
P4RC2	Validate Microcontroller Program ver 4.0

Overview

The RCU is built upon the Propeller Micro-Controller (uC), a unique device that contains 8 processors, called Cogs, that are each capable of being clocked at 80 MHz, and combined allows up to 160 Million Instructions Per Second (MIPS) (20 MIPS per Cog). Not only does the Propeller allow unprecedented processing power, it delivers that with a fairly easy to use programming language, SPIN, and a large user support system known as the Object Exchange.

The RCU is implemented off an Xbox-360 Wireless Controller. While the Analog inputs from the Xbox Controller are used, the digital inputs are not due to the complexities of the Xbox Controller's circuit board and an external button pad is attached. An LCD screen and GPS sensor are also included to extend the functionality of the RCU. See Appendix XX: RCU Electrical Schematic for more information. The RCU communicates with the Vehicle and the GCS through a XBee wireless network.

Comment [DPG21]:

For a diagram of the Remote Control, see Figure 18: RCU Block Diagram

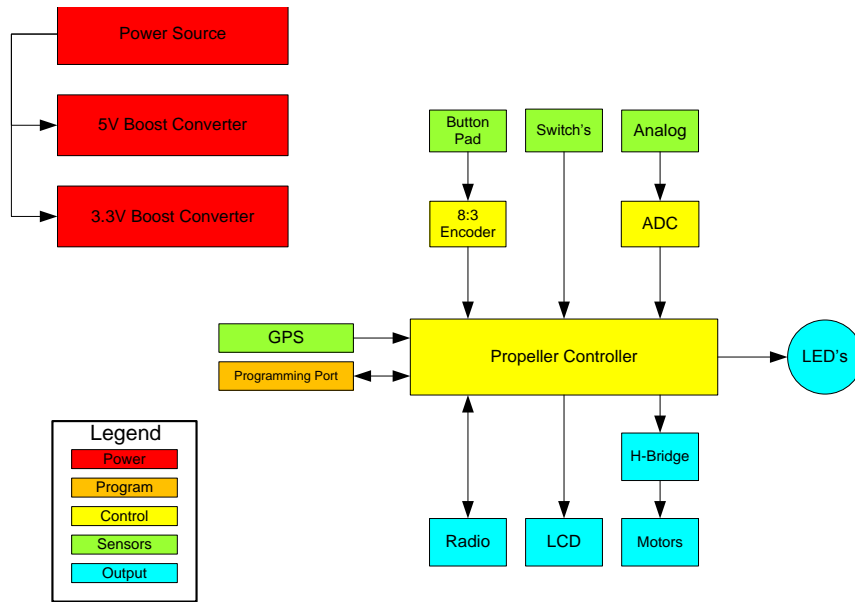
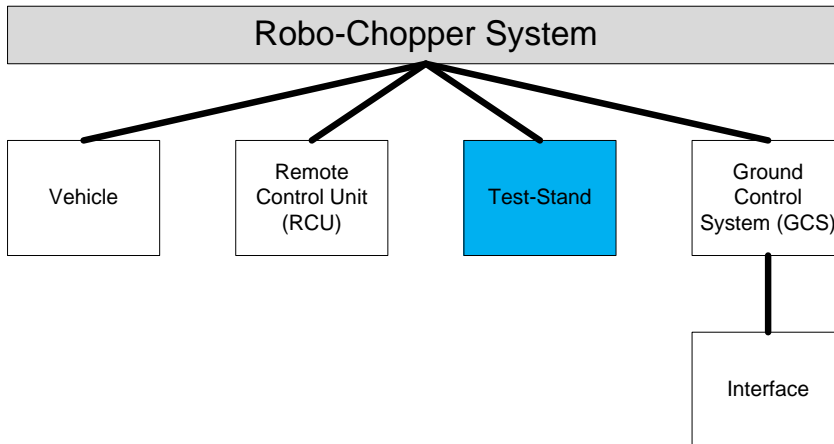

Figure 18: RCU Block Diagram

System - Test Stand



Summary

The Test Stand has been designed to facilitate calibration and functional testing of different parameters of the control system used on the Vehicle. It allows a magnetic coupler to connect to the Robo-Chopper, continuous horizontal rotation, limited vertical travel, lift-force measurement and a power to allow extended functional tests of different sub-systems on the Vehicle. The Test-Stand consists of 4 Sub-Systems, the Frame, Force Measurement, Power and Test Fixture Assembly.

Budget

Table 24: Test-Stand Budget

<i>Subsystem</i>	<i>Amount</i>
Frame	\$1034.92
Test Fixture	\$30.02
Power	
Force Measurement	
Total:	

Action Item List

Table 25: Test-Stand Action Item List

P1TS	Test-Stand
P1TS1	Design Test-Stand
P1TS1-A	Source Test Fixture Attachment hardware
P1TS2	Order Parts
P1TS3	Build Test-Stand
P1TS3-A	Find Machine shop to fabricate sub-system
P1TS3-B	Procure tools to fabricate sub-system
P1TS3-C	Fabricate all parts
P1TS3-D	Assemble all subsystems
P1TS3-E	Assemble Test-Stand
P1TS3-F	Incorporate Weight Scales into Test Stand
P1TS3-G	Design and Source Power electronics
P1TS3-H	Design and Source Magnetic Coupler electronics
P1TS4	Calibrate Test Stand
P2TS	Test-Stand
P2TS1	Build Test-Stand Vehicle Attachment Fixture
P2TS2	Assemble Electronics

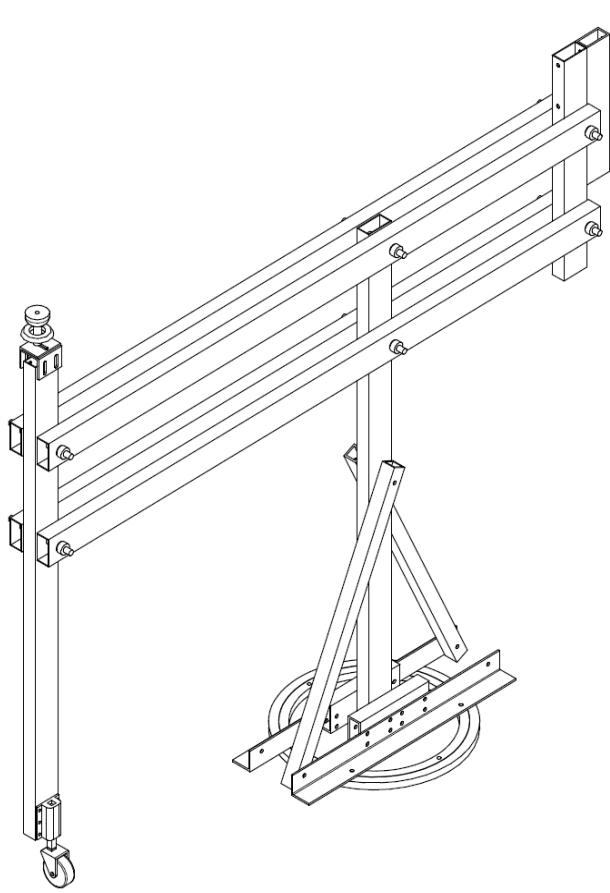

Comment [DPG22]: Picture Obsolete

Figure 19: Test-Stand Design

Subsystem – Frame

Overview

The Frame Subsystem was designed using Aluminum rectangle and square tubing as appropriate. The “Lazy-Susan”, a component that includes a rotating inner ring and a fixed outer ring, offers continuous horizontal rotational movement of the Test-Stand. The upper assembly is on a pivot,

and coupled with an adjustable counter-weight and a spring-loaded caster wheel under the Vehicle, allows for limited vertical travel. See Appendix: **XX** for Design Drawings of the Test-Stand.

Comment [DPG23]:

Component Selection and Specifications

Subsystem – Force Measurement

Overview

Force measurement is available with a digital scale attached directly underneath the counter-weight. When the Vehicle is operated it will generate lift which will push the counter-weight against the scale and when scaled appropriately will measure the lift generated by the Vehicle. By using different counterweights, The Frame assembly weight can be offset and/or the entire weight of the Vehicle as well. This allows direct measurement of the lift generated by the Vehicle without having to subtract for the weight of the Vehicle (i.e. when baseline lift measurements are required). See Appendix: **XX** for Test Stand Calculations.

Comment [DPG24]:

Component Selection and Specifications

Subsystem – Electronics

Overview

Power is delivered by a 480 Watt power supply, giving up to 12 Volts of 40 Amps of direct-current power. It is transferred through a slip-ring on the bottom of the lazy-susan (not shown) that allows continuous horizontal rotational movement of the Test-Stand. A 120 Amp Circuit Breaker/Main Power Switch is installed to protect the Vehicle and/or power supply from short circuits. See Appendix: **XX** for an electrical schematic of the Electronics Subsystem.

Comment [DPG25]:

Component Selection and Specifications

Power Supply

Slip-Ring

Subsystem – Test Fixture Assembly

Overview

The Vehicle is attached to the Test-Stand through the Test Fixture Assembly (TFA). The TFA consists of a ball joint that can swivel +/- 30 degrees from a horizontal plane and a pair of electro-magnets that are powered via the 120 Amp Circuit Breaker/Main Power Switch and are matched with a pair of metal plates on the Vehicle. Magnets were chosen not to be used on the Vehicle due to their interference with the electronic Compass.

Component Selection and Specifications

System – Ground Control Station

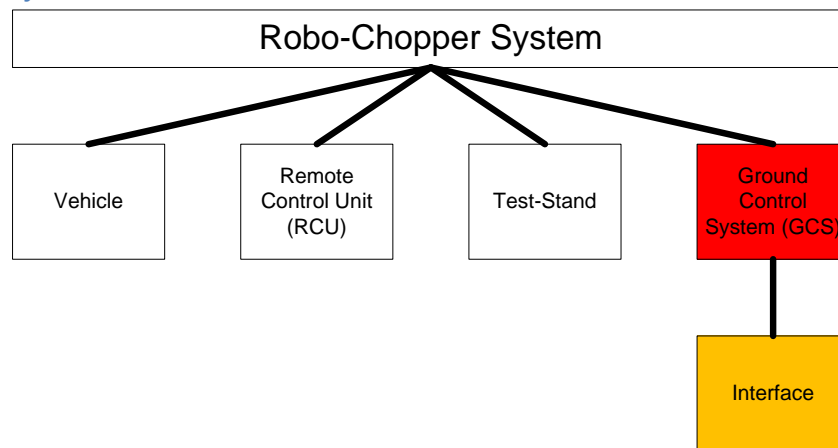

Summary

The Ground Control Station (GCS) is a transportable case used to provide manual and autonomous control of the Vehicle. It accomplishes this in a mobile fashion by having DC 12V batteries, a computer and a LCD touch-screen monitor, a DC power inverter to power the computer and an antenna mast for communications to the Vehicle and the GCS.

The GCS Interface (GCSI) is designed to provide not only Manual Control of the Vehicle but also to provide a Graphical User Interface (GUI) for Autonomous Control of the Vehicle as well, using satellite images available from Google Earth. Manual Control of the Vehicle is provided by either a Keyboard or

an attached and appropriately configured Xbox-360 Controller. The GCSI is programmed using National Instrument's LabView, a graphical programming language.

For instructions on how to use the GCS, see Appendix XX: GCS Operating Manual. The GCS consists of 4 Sub-Systems, the Case, Power, Control and Communications Sub-Systems.

Comment [DPG26]:

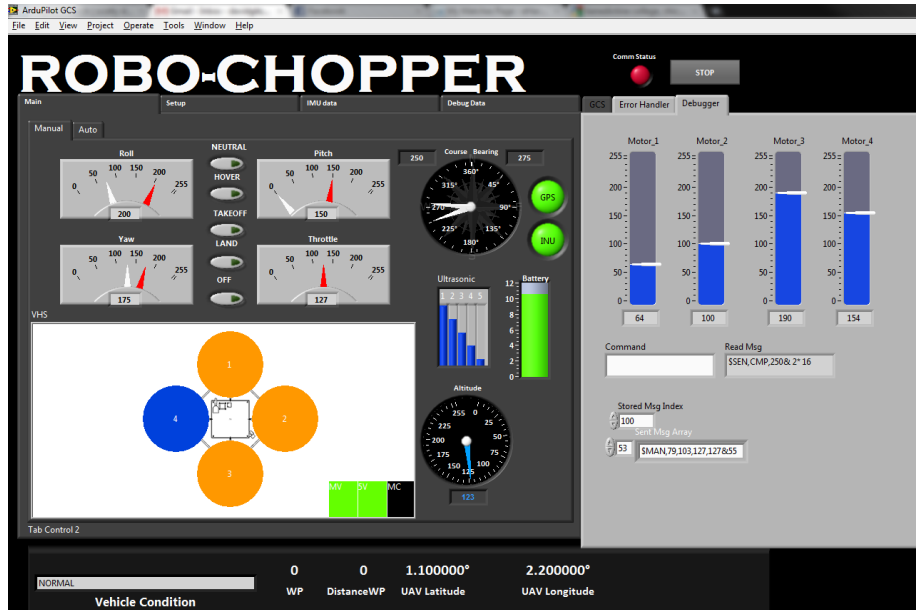

Figure 20: GCSI Manual Control



Figure 21: GCS Communications Tab

Budget

Table 26: GCS Budget

<i>Subsystem</i>	<i>Amount</i>
Case	
Power	
Control	
Communications	
Total:	

Comment [DPG27]:

Action Item List

Table 27: GCS Action Item List

P1GS	Ground Control Station
P1GS1	Design Ground Station
P1GS2	Build Ground Station
P1IN	Interface
P1IN1	Develop Interface Program ver 1.0
P1IN2	Validate Interface Program ver 1.0

P2IN	Interface
P2IN1	Develop Interface Program ver 2.0
P2IN2	Validate Interface Program ver 2.0
P3IN	Interface
P3IN1	Develop Interface Program ver 3.0
P3IN2	Validate Interface Program ver 3.0
P4IN	Interface
P4IN1	Develop Interface Program ver 4.0
P4IN1	Validate Interface Program ver 4.0

Subsystem – Case

Overview

The GCS Case is developed from an after-market military field transportable case. It is of rugged construction, moisture resistant and easily configurable. Several items have been fastened to the Case, such as gas-springs to hold the lid of the Case open, telescopic tubes for the communications mast and foam has been inserted in the Case to position the components inside with little shifting. See Figure 22: GCS Case Opened and Figure 23: GCS Case Closed for a diagram of the GCS Case.

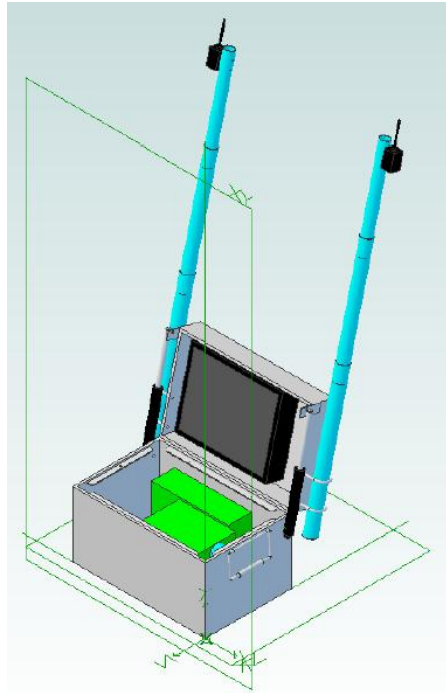

Figure 22: GCS Case Opened

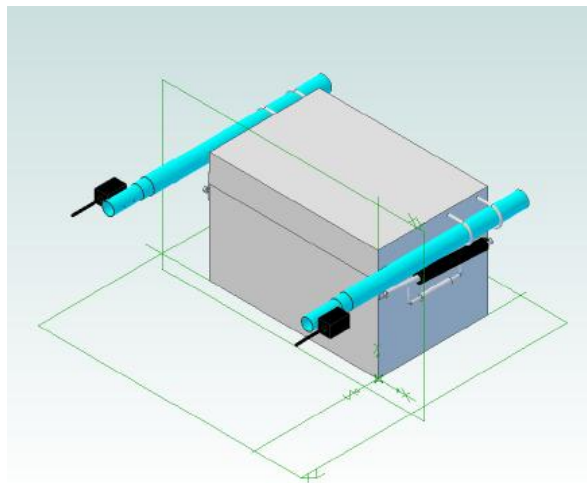

Figure 23: GCS Case Closed

Component Selection and Specifications

Subsystem – Power

Overview

The GCS is powered by 2 12 Volt Sealed Lead Acid (SLA) batteries configured to deliver up to 24 Amp-Hours of capacity. Since they are of the SLA construction, they are much more resistant to vibration and orientation issues. From the 12 Volt batteries power goes to a DC Power Inverter to generate 110 Volts AC to power the Control Subsystem.

Component Selection and Specifications

Table 28: Battery Backup Selection Matrix

<i>Specification</i>	<i>Minimum Requirement</i>	<i>Powersonic PS-12120F2</i>	<i>MK ES12-12</i>	<i>Powersonic PS-12260-F2</i>
Battery Type	12V SLA	12V SLA	12V SLA	12V SLA
Terminals		.250 fastion		
Capacity	>26 (OEM) Amp-Hours	12 Ah	12 Ah	26 Ah
Dimensions (in)			5.94" x 3.94" x 3.9"	6.6" x 6.9" x 5"
Weight (lbs)		8.55	9.39	17.1
Price		\$43.19	\$57.95	\$60.29
Other Features				OEM
Vendor		Batteries Plus	Apex Battery	atbatt
Website		Link	Link	Link

Table 29: DC Power Inverter Selection Matrix

<i>Specification</i>	<i>Minimum Requirement</i>	<i>Cobra C128-1026</i>	<i>DCACPOWERINVERTS.COM PW400-12</i>	
Power Output	>250 W	1000 W	400 W	
Outlets	>1	2	2	
Cooling		Fan/Case Heatsink	Fan/Case Heatsink	
Power Input Type		Wired Connectors	Wired Connectors	
Dimensions (in)			5" x 2" x 7.4"	
Weight (lbs)			2.6	
Price		\$84.99	\$34.99	
Other Features				
Vendor				
Website			Link	

Subsystem – Communications

Overview

An XBee Radio is mounted to a telescopic communications mast that increases the height of the XBee to approximately 4 feet. This communications mast has been designed due to the effects of the Test Plan study. It was determined in the Test Plan that increased height can increase the range of the XBee Radio as long as there are no power couplings on the antenna, so the XBee will be mounted to the top of the communications mast and the data cable will be connected to the GCS computer via USB Cables. In the future, if a Video unit is included in the GCS a second communications mast will be added on the other side of the Case.

Comment [DPG28]: Which one?

Component Selection and Specifications

See

Comment [DPG29]:

Subsystem – Control

Overview

A computer and a touch-screen LCD have been integrated into the GCS Case. This allows the operator to have complete control of the Vehicle in a field appropriate setting. There is also a USB hub attached to the computer so a Xbox-360 Controller can be used to fly the Vehicle manually, and optionally a keyboard and mouse can be attached as well for configuration and troubleshooting.

Component Selection and Specifications

Table 30: Computer Selection Matrix

Specification	Minimum Requirement	Advantech UNO-2173A-A12E-250G-XPP	Puget Echo II	
CPU		Intel Atom 1.6 GHz	Intel 2.8 GHz Dual Core	
On Board RAM	1 GB SDRAM	1 GB SDRAM	2 GB DDR3	
VGA/Mouse/Keyboard		1 VGA	1 DVI, 1 HDMI	
Graphics Card				
Serial Port		2xRS-232		
Ethernet Port	1	1	1	
USB Port	2	2	2 (4)	
PC Expansion Slot		1X Mini-PCIe	1x PCIe (x16)	
Hard Drive	250 GB	2G0 GB	320 GB	
Operating System	Windows XP	Windows XP Pro	Windows 7 Home – 64 Bit	
Optical Drive			Sony 8x DVD-RW	
Power Input		9 ~ 36 VDC		

Power Consumption		15 W	150 W	
Cooling			Fanless, Heatsink	
Weight				
Case Style			Mini ITX	
Dimensions		10" x 6" x 2.3"	12.9" x 8.7" x 3.8"	
Price		\$769.00	\$821.38	
Other Features				
Vendor		Advantech	Puget	
Website			Link	

Table 31: LCD Touchscreen Selection Matrix

Specification	Minimum Requirement	ELO Touchsystems 1247L		
Touchscreen Type		5-wire Resistive		
Screen size		12.1"		
Recommended Resolution		800 x 600		
Brightness		320 cd/m ²		
Contrast Ratio		500:1		
Touchscreen Interface		USB		
Input Video Connector		D-Sub		
Power Input				
Power Consumption		11.98 W		
Dimensions	< 16.5" (L) x 10.5" (W) x 2.5" (H)	11.9" x 9.5" x 2.4"		
Weight (lbs)		8.8		
Price		\$564.00		
Other Features		Easily mountable, 3d design available		
Vendor		ELO		
Website		Link		

References

[1] [http://en.wikipedia.org/wiki/Lift_\(force\)](http://en.wikipedia.org/wiki/Lift_(force))

Appendix

- A. Documents produced by Team
 - 1. Test-Stand Design Drawings
 - 2. Test-Stand Calculations
 - 3. Remote Control Unit Design Report
 - 4. Robo-Chopper Communications Protocol
 - 5. Test-Stand Electrical Schematic
 - 6. GCS Operating Manual
 - 7. Filter Design
 - 8. INU Design
 - 9. RCU Electrical Schematic
 - 10. SNR Model
 - 11. Test Plans

Figures

Figure 1: Project Phase Plan.....	7
Figure 2: Communication Link Diagram	10
Figure 3: Data Packet Detail	11
Figure 4: 3-Way Handshake	12
Figure 5: Vehicle Rotor Diagram	13
Figure 9: Phase 2 Control System	15
Figure 10: Phase 2 Secondary Controller Block Diagram	16
Figure 11: Phase 3 Control System	17
Figure 12: Phase 3 Primary Controller Block Diagram	18
Figure 13: Phase 3 Secondary Controller Block Diagram	18
Figure 14: INU Diagram	19
Figure 6: 9600 Baud w/ High Antenna	20
Figure 7: 115200 Baud w/ High Antenna	21
Figure 8: 115200 Baud w/ Low Antenna	21
Figure 16: Vehicle Picture	24
Figure 15: Vehicle System Responsibility Diagram	26
Figure 17: Vehicle CAD Design	Error! Bookmark not defined.
Figure 18: RCU Block Diagram.....	38
Figure 19: Test-Stand Design	41
Figure 20: GCSI Manual Control	44
Figure 21: GCS Communications Tab	45

Figure 22: GCS Case Opened	47
Figure 23: GCS Case Closed	47

Tables

Table 1: Suggested Customer Applications	4
Table 2: Project Budget	5
Table 3: Minimum Baud Rate Calculations	11
Table 4: Lift Force Calculations	14
Table 5: Dropped Packet Measurement Results	22
Table 6: Vehicle Budget	26
Table 7: Vehicle Action Item List	27
Table 8: Gyroscope Selection Matrix	28
Table 9: Accelerometer Selection Matrix	29
Table 10: Altimeter Selection Matrix	29
Table 11: Compass Selection Matrix	30
Table 12: Ultrasonic Selection Matrix	30
Table 13: GPS Selection Matrix	31
Table 14: Encoder Selection Matrix	31
Table 15: Battery Selection Matrix	32
Table 16: Electronic Speed Controller Selection Matrix	33
Table 17: Motor Selection Matrix	33
Table 18: Propeller Selection Matrix	34
Table 19: Radio Selection Matrix	35
Table 20: RCU Budget	36

Table 21: RCU Action Item List..... **Error! Bookmark not defined.**

Table 22: Test-Stand Budget 39

Table 23: Test-Stand Action Item List **Error! Bookmark not defined.**

Table 24: GCS Budget..... 45

Table 25: GCS Action Item List **Error! Bookmark not defined.**

Table 26: Computer Selection Matrix 49

Table 27: LCD Touchscreen Selection Matrix..... 50

Table 28: Battery Backup Selection Matrix **Error! Bookmark not defined.**

Table 29: DC Power Inverter Selection Matrix..... 48